

Scheda tecnica

# MORSETTI ATTACCO TONDO

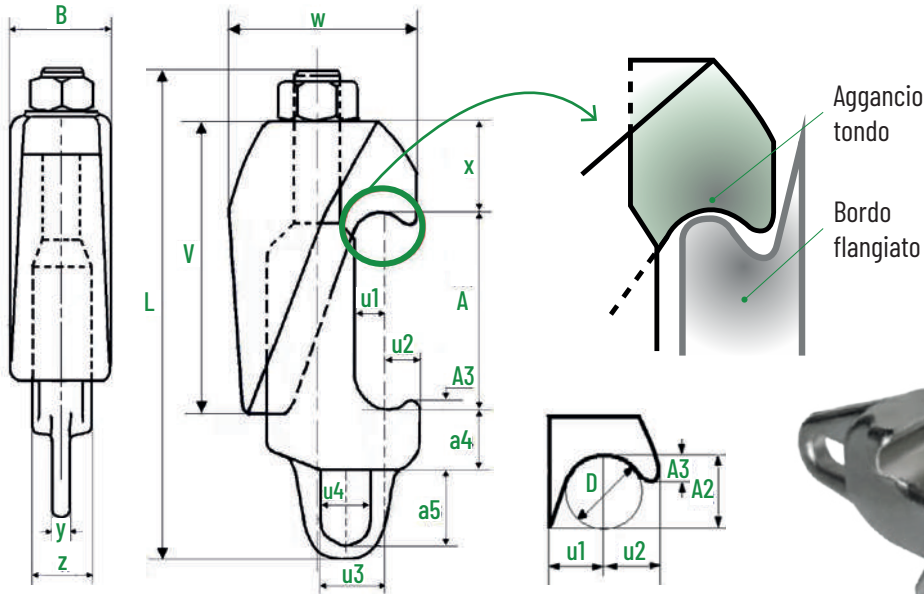

**MATERIALI**

- acciaio legato: 25CrMo4 sec. DIN EN 10269
- acciaio inox: AISI 316L / ASTM A193 Gr.B8M
- altri materiali: su richiesta

**FINITURE**

- zincatura elettrolitica gialla/bianca
- passivazione, lucidatura a specchio, elettro lucidatura
- altre finiture: su richiesta

**CERTIFICATI**

- EN 10204 3.1: con tutte le forniture
- EN 10204 3.2: su richiesta



**ASSEMBLAGGIO STANDARD**



Dado esagonale passante sec. UNI 5587



Dado esagonale cieco sec. UNI 5587

Altri tipi di chiusura su richiesta

| Modello | A Apertura | L   | B  | A2 max | A3 max | D min | u1 min | u2 max | u3 min | u4 min | a4 max | a5 min | V   | w   | x  | y  | z  | Kg   |
|---------|------------|-----|----|--------|--------|-------|--------|--------|--------|--------|--------|--------|-----|-----|----|----|----|------|
| M16     | 50-75      | 180 | 45 | 17     | 5      | 16    | 11     | 12     | 22     | 20     | 20     | 33     | 86  | 62  | 24 | 10 | 27 | 1,40 |
| M16     | 95-120     | 225 | 45 | 17     | 5      | 16    | 11     | 12     | 22     | 20     | 20     | 33     | 86  | 62  | 24 | 10 | 27 | 1,50 |
| M20     | 60-85      | 195 | 50 | 20     | 5      | 16    | 12     | 12     | 22     | 20     | 22     | 33     | 95  | 69  | 24 | 10 | 30 | 1,80 |
| M20     | 95-120     | 235 | 50 | 20     | 5      | 16    | 12     | 11     | 22     | 20     | 22     | 33     | 95  | 69  | 24 | 10 | 30 | 2,50 |
| M24     | 75-100     | 217 | 54 | 20     | 6      | 20    | 14     | 14     | 30     | 20     | 25     | 30     | 112 | 74  | 26 | 10 | 35 | 2,61 |
| M24     | 90-115     | 233 | 54 | 20     | 6      | 20    | 14     | 14     | 30     | 20     | 25     | 30     | 112 | 74  | 26 | 10 | 35 | 2,71 |
| M24     | 110-135    | 252 | 54 | 20     | 6      | 20    | 14     | 14     | 30     | 20     | 25     | 30     | 112 | 74  | 26 | 10 | 35 | 3,00 |
| M24     | 150-185    | 303 | 54 | 20     | 6      | 20    | 14     | 14     | 30     | 20     | 25     | 30     | 112 | 74  | 26 | 10 | 35 | 3,20 |
| M27     | 85-120     | 288 | 60 | 13     | 6      | 24    | 14     | 15     | 40     | 24     | 40     | 40     | 155 | 90  | 38 | 8  | 42 | 5,00 |
| M27     | 120-155    | 323 | 60 | 13     | 6      | 24    | 14     | 15     | 40     | 24     | 40     | 40     | 155 | 90  | 38 | 8  | 42 | 5,30 |
| M27     | 155-190    | 357 | 60 | 13     | 6      | 24    | 14     | 15     | 40     | 24     | 40     | 40     | 155 | 90  | 38 | 8  | 42 | 5,50 |
| M30     | 85-120     | 288 | 60 | 13     | 6      | 24    | 14     | 17     | 40     | 24     | 40     | 40     | 155 | 90  | 38 | 8  | 42 | 5,40 |
| M30     | 120-155    | 323 | 60 | 13     | 6      | 24    | 14     | 17     | 40     | 24     | 40     | 40     | 155 | 90  | 38 | 8  | 42 | 5,70 |
| M30     | 155-190    | 357 | 60 | 13     | 6      | 24    | 14     | 17     | 40     | 24     | 40     | 40     | 155 | 90  | 38 | 8  | 42 | 5,90 |
| M33     | 120-160    | 375 | 70 | 15     | 6      | 24    | 16     | 15     | 42     | 24     | 56     | 50     | 200 | 100 | 50 | 20 | 70 | 8,80 |
| M33     | 180-220    | 440 | 70 | 15     | 6      | 24    | 16     | 15     | 42     | 24     | 56     | 50     | 200 | 100 | 50 | 20 | 70 | 10,2 |

**Misure sec. DIN 28152 | Variazioni misure: su richiesta**

Ci riserviamo di apportare modifiche senza alcun preavviso